

CRANE[®]

brands you trust.



Crane[®]FKX 9000
Next Generation Triple Offset Valves

CRANE[®]

Crane ChemPharma & Energy

www.cranecpe.com

Heritage of Innovation & Quality

Crane Co. is a diversified manufacturer of highly engineered industrial products, founded in 1855. Crane has approximately 11,000 employees in the Americas, Europe, Asia and Australia, and is traded on the New York Stock Exchange (NYSE:CR).

Since its foundation in 1855, Crane has been a symbol of manufacturing excellence, expanding alongside the global industrial revolution and shaping the growth of industry worldwide. Crane ChemPharma & Energy, within Crane's Fluid Handling segment, is proud to be a part of the company's illustrious history, delivering solutions to the fluid handling challenges faced by the industry's most demanding applications.

From the industrial revolution to the modern age, Crane has anticipated the challenges of the market and developed progressive solutions to address them.

A comprehensive product portfolio backed by a robust global infrastructure enables Crane CP&E to deliver localized solutions to the chemical processing, biotechnology, pharmaceutical, oil & gas, refining, and power generation industries worldwide. Crane CP&E's highly-engineered offering includes check valves, sleeved plug valves, lined valves, process ball valves, high-performance butterfly valves, bellows sealed globe valves, aseptic and industrial diaphragm valves, multi/quarter-turn valves, actuation, sight glasses, lined pipe, fittings and hoses, and air operated diaphragm and peristaltic pumps.

With offices, manufacturing plants, distribution networks, and sales & service centers that span the globe, Crane CP&E is a worldwide leader in fluid handling products and solutions.

Crane Fluid Handling: Global Presence, Local Support.



Traceability

A stainless steel, tag is attached to all manufactured and modified valves. It includes standard ASME information.

Fully Tested

All valves manufactured by Crane® are tested in accordance with Crane® strict manufacturing procedures and industry regulations.

Field Repair Services

Crane® technicians are available for field repair and emergency service at your site.

Consistent Quality

The high Crane® quality is supported by our extensive practical experience, state-of-the-art manufacturing, and quality assurance certified by international inspections authorities. Please visit our website for details.

Features and Benefits

The Crane®FKX 9000 Triple Offset Valves valve design is recommended for industrial applications requiring reliable zero-leakage, bi-directional shut-off in harsh conditions of critical processes, steam isolation, and temperature extremes; especially when use of soft-seated materials in valves is limited.

Compared to ball valves, the Crane®FKX 9000 Triple Offset Valves is an affordable solution, particularly in larger diameter installations, that requires less structural support to ensure bubble tight shut-off. The result is a virtual zero leakage shut-off even in high-pressure, high-temperature applications. Due to their quarter-turn movement for opening and closing, the valves are easy to automate and they can fulfill a quick closing time, which is often required in safety applications.

Features and Benefits

- 1 Optimized Seat Angle:** An innovative seat angle design and Stellite® hard-faced valve body seat deliver a longer seal life and improved abrasion resistance, even after extensive cycling. Designed to eliminate wedging or binding of the disc, and lower the operating torque, the Crane®FKX 9000 can **REDUCE TOTAL COST OF OWNERSHIP BY UP TO 50%.***
- 2 Metal-to-Metal Sealing:** The precision machined metal seat and seal ring deliver reliable and bi-directional shutoff in high-temperature, high-pressure and severe service applications among others. The right-angle conical seat design facilitates an almost **FRICTION-LESS IN-LINE SEALING.**
- 3 Innovative Shaft Seal Design:** permits superior FUGITIVE EMISSIONS CONTROL (ISO 15848, Class AH) under recurrent thermal cycling, **and REDUCES POTENTIAL DOWN TIME.**
- 4 Torque-Seating:** Unlike position-seated ball, butterfly or plug valves, the torque-seated Crane® FKX 9000 self-adjusts to evenly distribute seal compression. A “floating” seal ring and wide seal ring supporting gasket yield a **BETTER SEAL** to eliminate binding and to enhance performance.

**Proven against leading TOV supplier, in customer's Methyl Di Isocyanate application*

What is a TOV?

As the name implies, there are three separate offsets designed into the valve. Two of the offsets apply to the location of the shaft with respect to the center line of the bore and the center line of the disc/seat sealing surfaces. The third offset in the design is the axis of the seat cone angle that is inclined from the center line of the valve bore to eliminate rubbing of the seat/seal contact surfaces during operation and to preserve sealing integrity over the cycle life of the valve. The contact is made in only the final point of closure, acting as a mechanical travel stop. This prohibits overtravel of the disc. The wide angle seat also eliminates wedging or binding of the disc.

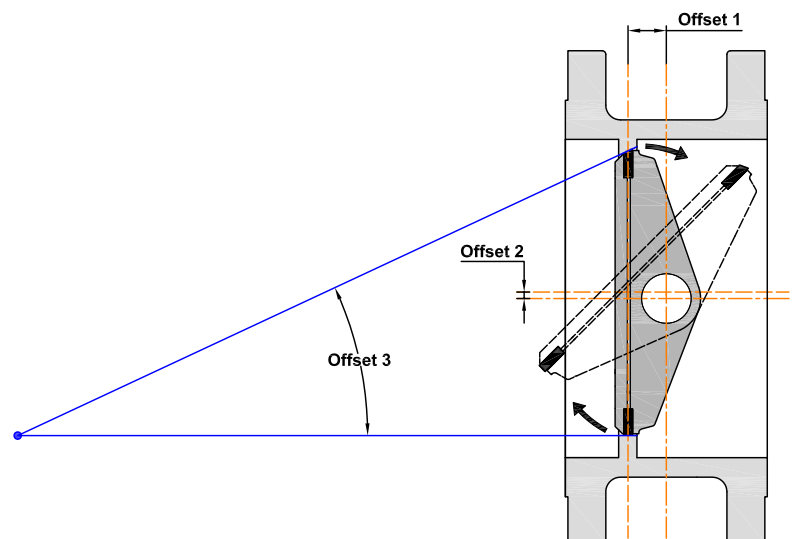

Product Overview

Materials of Construction

- Standard: A216 Gr. WCB, A351 Gr. CF8M
- Options (upon request): Duplex, Superduplex, LCC/LCB, WC6, CF3M, Monel®, Inconel®, Hastelloy®, Alloy 20

Size Range

- 3" up to 48", in a single piece cast body

Pressure Ratings

- ASME Class 150#, Class 300#

| DN (mm) | NPS (inch) | Lug | | DFS | | DFL | |
|------------|---------------|--------------|--------------|--------------|--------------|--------------|--------------|
| | | Class 150 | Class 300 | Class 150 | Class 300 | Class 150 | Class 300 |
| 80 | 3 | ● | ● | ● | ● | ● | ● |
| 100 | 4 | ● | ● | ● | ● | ● | ● |
| 150 | 6 | ● | ● | ● | ● | ● | ● |
| 200 | 8 | ● | ● | ● | ● | ● | ● |
| 250 | 10 | ● | ● | ● | ● | ● | ● |
| 300 | 12 | ● | ● | ● | ● | ● | ● |
| 350 | 14 | ● | ● | ● | ● | ● | ● |
| 400 | 16 | ● | ● | ● | ● | ● | ● |
| 450 | 18 | ● | ● | ● | ● | ● | ● |
| 500 | 20 | ● | ● | ● | ● | ● | ● |
| 600 | 24 | ● | ● | ● | ● | ● | ● |
| 700 | 28 | - | - | ● | ● | ● | ● |
| 750 | 30 | - | - | ● | ● | ● | ● |
| 800 | 32 | - | - | ● | ● | ● | ● |
| 900 | 36 | - | - | ● | ● | ● | ● |
| 1000 | 40 | - | - | ● | - | - | - |
| 1050 | 42 | - | - | ● | - | - | - |
| 1200 | 48 | - | - | ● | - | - | - |

Temperature Range

- -76°F up to 1022°F; -60°C up to 550°C, depending on material selection

Body Configurations

- Lug: API 609 Cat. B Table 3
- Double Flanged Short Pattern: API 609 Cat. B Table 3, ISO 5752 Series 13, EN 558 Series 13
- Double Flanged Long Pattern: API 609 Cat. B Table 3, ISO 5752 Series 3 - cl.150, ISO 5752 Series 4 - cl.300, AMSE B16.10 flanged gate valves

Special Options

- Capable to meet ISO 15848 Class A, level C02
- Monitoring & flushing ports for cleaning stuffing box area by purging contaminants
- Pressure tight bearing protector
- Graphite-free, full metal seal ring
- API 6D test is available by request

Compliance

- API 609 and ASME B16.34 valve design standard
- Zero leakage as per API 598
- API 607, 6th edition: Fire Tested
- EPA Method 21 (Fugitive Emissions Compliance)
- ISO 15848, Class BH, level C03 is our standard offering. Class AH, level C02 is an optional offering
- Quality certification as per ISO 9001



Applications

A triple eccentric or triple offset butterfly valves should be used when the application requires bubble tight shut-off but does not allow the use of a rubber-lined butterfly valve due to low/high temperatures and high pressure.

Crane[®] FKX 9000 - Performance Chart

| FUNCTION | | MEDIA TYPES | | | | | | | | APPLICATION REQUIREMENTS | | | | | | | | | |
|----------|------------|-----------------------|-----------------------|---------------------------|-------------------|-----------------|-------------------|----------------------|----------------|--------------------------|------------|----------------------------|----------------------------|---------------------|----------------|----------|-------------------|------------------|-----------------|
| On / Off | Throttling | Clean Liquids & Gases | Dirty Liquids & Gases | Corrosive Liquids & Gases | Hazardous Liquids | Viscous Liquids | Abrasive Slurries | Extreme Temperatures | Vacuum Service | Extended Service Life | Low Torque | Fugitive Emissions Control | Minimal Space Requirements | Reduced Maintenance | Bi-directional | Sizes | Pressure Range | High Temperature | Low Temperature |
| ● | ● | ● | ● | ● | ● | ● | ● | ● | ● | ● | ● | ● | ● | ● | ● | 3" - 48" | Class 150/300/600 | 1022°F / 550°C | -76°F / -60°C |

● Well Suited ● Limited Application









Industries

- Oil & Gas Processing
- Refineries
- Hydrocarbons Storage & Transportation
- Chemical & Petrochemical Plants
- Power Generation
- Offshore Platforms
- District Heating
- Pulp & Paper
- Steel Mills
- Sugar Mills
- Desalination Plants
- Water Treatment & Distribution

Processes

- Steam (Saturated & Superheated)
- Hydrocarbons
- Hydrogen
- Oxygen
- Hot gases
- Sulphur (Tail Gas)
- Chlorinated Solvents
- Flare Gas
- Chemical Solvents

Design Versions

| | Lug Design | Double Flanged Short Pattern Design | Double Flanged Long Pattern Design |
|-------------------------|---|---|---|
| Front View - Shaft side |  |  |  |
| Side View |  |  |  |
| Top View |  |  |  |

Design Features

Top flange standard design acc. to ISO 5211

Monitoring Port as option

Flushing Port as option

Low emission packing for ISO 15848-Class A (<50ppm), EPA Method 21 & TA-Luft compliance as option

Pressure-tight bearing protector as option

Stellite[®] seat with wide seat angle for longer seat life as standard

Replaceable Graphite/Stainless Steel laminated seal-ring (laminated full metal seal-ring optional)

Fixed disc with flexible, resilient metal seal ring

Stainless steel bearing (ASTM A582 Gr.303) designed to minimize shaft deflection

Shaft retainer with pin

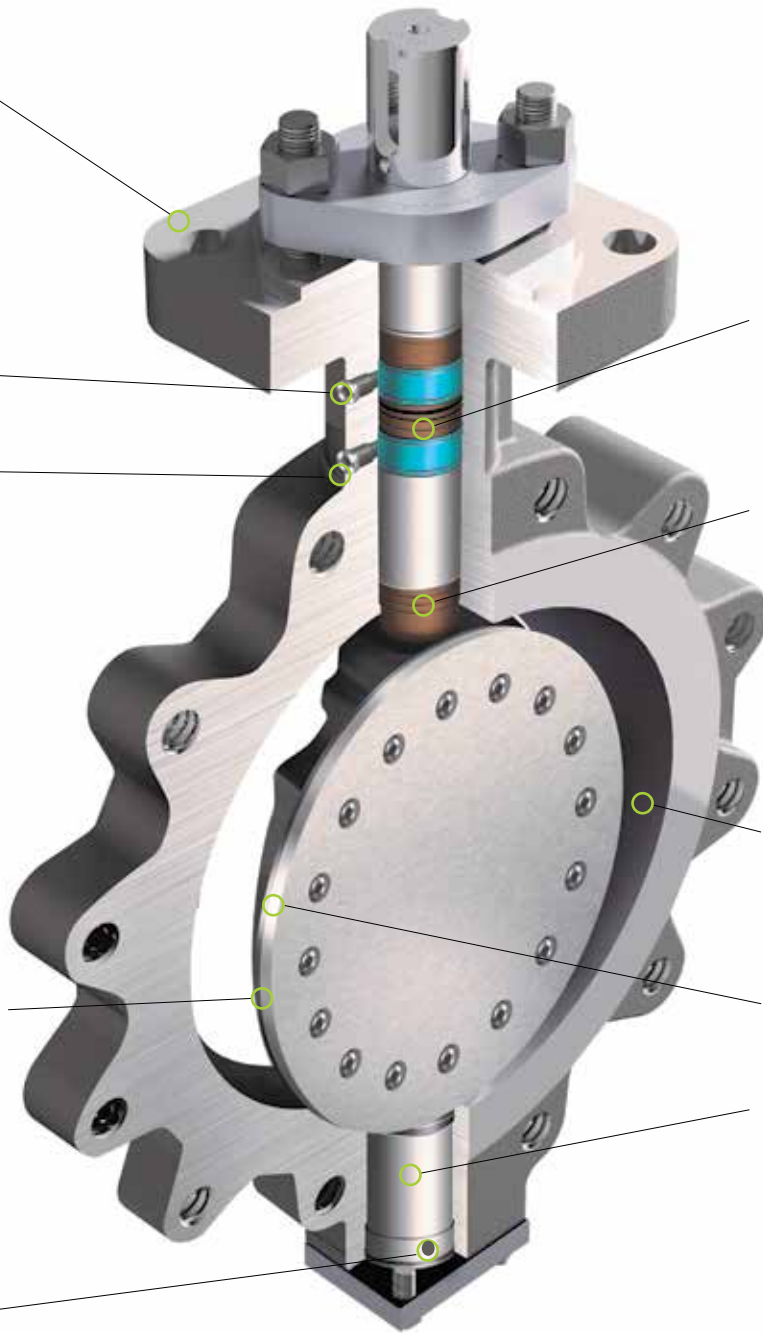

Design Features

Shaft Packing & Ports

- Standard: ISO 15848-1&2: Class BH (< 100 ppmv)
- Option: ISO 15848-1&2: Class AH (< 50 ppmv) for lower emissions services

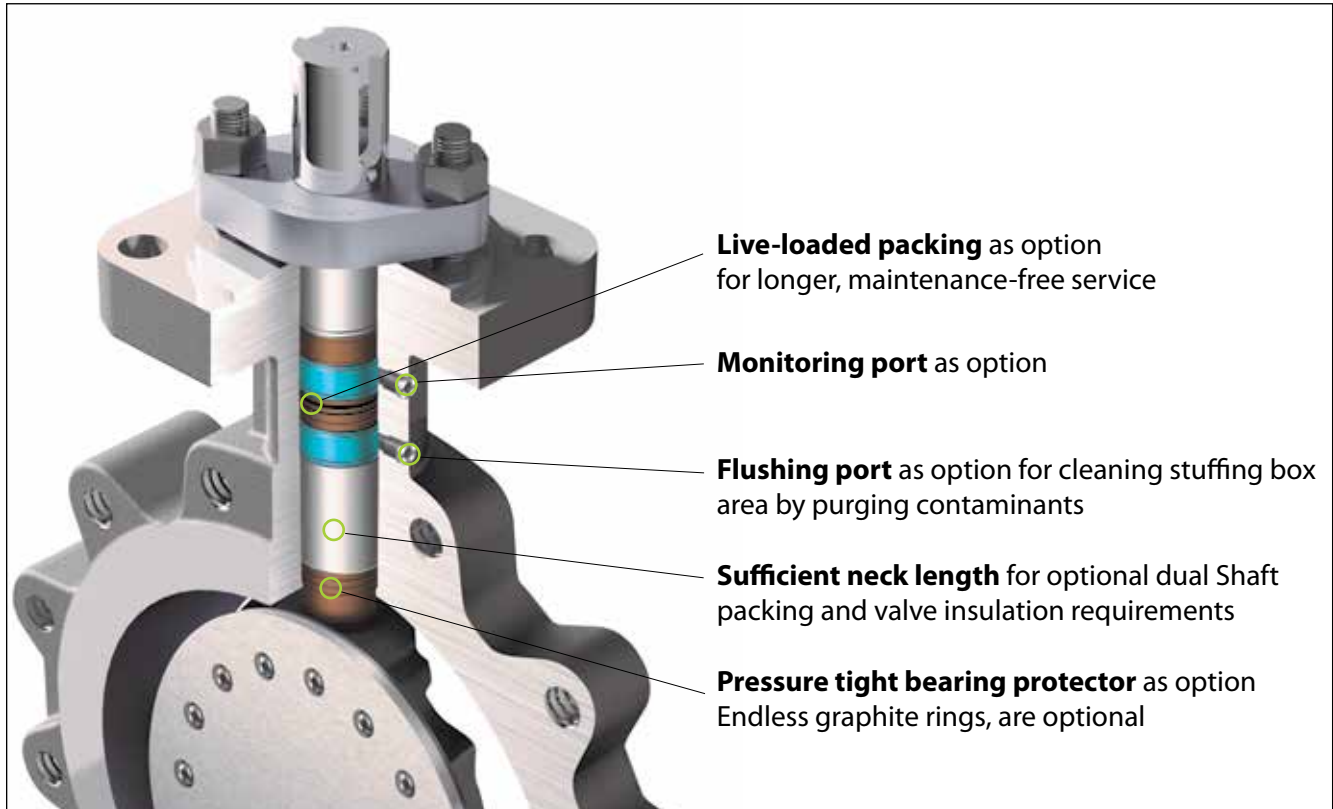

Optimized Seat Angle

- Friction-less shut-off for severe service or abrasive applications
- Enables longer service life by reducing seal wear
- Improved abrasion resistance: optional full-metal (no graphite) seal ring, combined with Stellite hard-facing of seat further enhances seal life and abrasion resistance

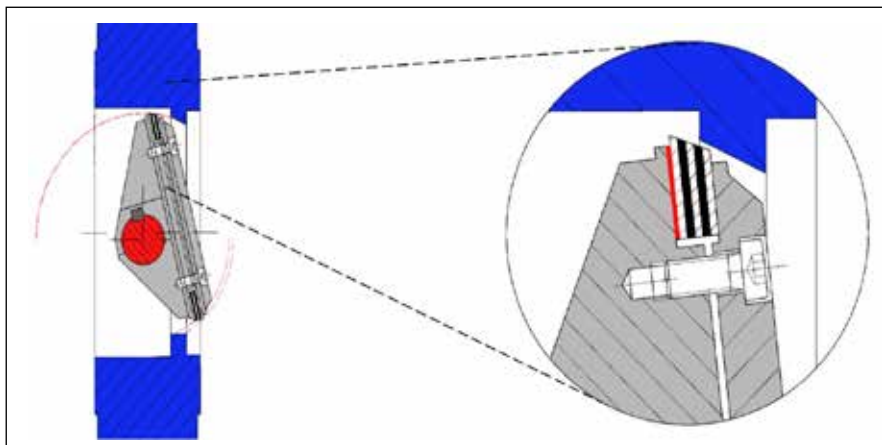

Design Features

Blow-Out Proof Shaft

- Shaft blow-out protection is a standard product feature
- Double safety feature: Shaft retainer pin and retaining ring prevents Shaft moving out of the body

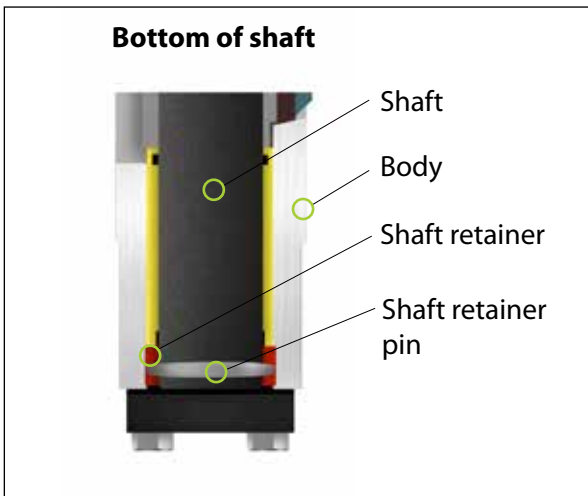
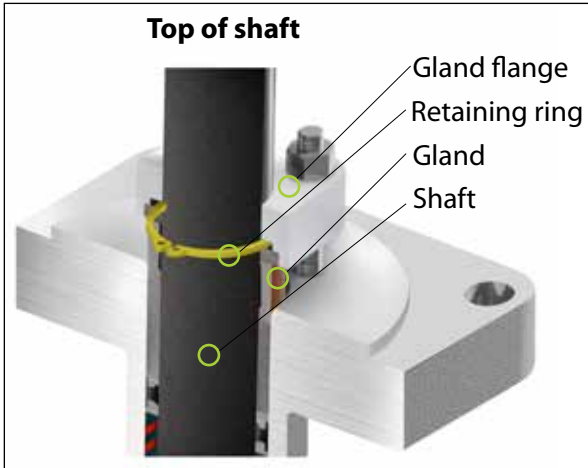

Standard Packing Gland Design

- Standard packing gland design prevents contamination of the packing

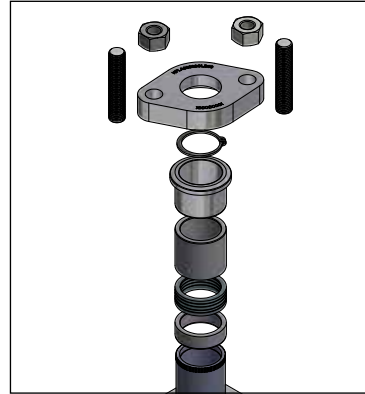

Optional Packing Gland Design

- Optional packing flange design for chemical applications

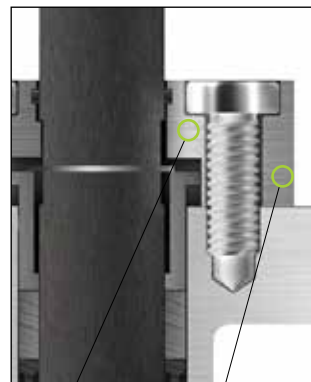
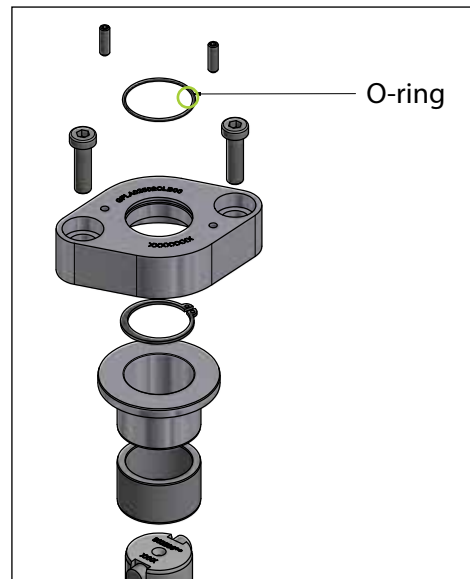

Secondary Shaft Seal Gland flush against top flange



Gland Adjustment Screws

Product Configuration

| Product Line | Valve Type | Material Group | Flange T |
|-----------------|------------|----------------|----------|
| Crane FKX 9000- | XNLG- | APB1- | A- |

| Valve Type | | | | | |
|------------|---------|----------|--------|------------|---|
| Size | | Pressure | | Body Style | |
| C | Value | C | Value | C | Value |
| L | 3 inch | N | 150# | LG | Lug type (API 609, table 3 category B) |
| M | 4 inch | P | 300# | DS | Double flanged - short pattern (ISO 5752, table 1, column 13) |
| P | 6 inch | R | 600# | DL | Double flanged - long pattern (ASME B16.10, long pattern) |
| R | 8 inch | B | PN 10 | X | Other |
| S | 10 inch | C | PN 16 | | |
| T | 12 inch | E | PN 25 | | |
| U | 14 inch | F | PN 40 | | |
| V | 16 inch | L | PN 63 | | |
| W | 18 inch | M | PN 100 | | |
| X | 20 inch | | | | |
| Y | 24 inch | | | | |
| Z | 28 inch | | | | |
| 1 | 30 inch | | | | |
| 2 | 32 inch | | | | |
| 3 | 36 inch | | | | |
| 4 | 40 inch | | | | |
| 5 | 42 inch | | | | |
| 7 | 48 inch | | | | |
| L | DN 80 | | | | |
| M | DN 100 | | | | |
| N | DN 125 | | | | |
| P | DN 150 | | | | |
| R | DN 200 | | | | |
| S | DN 250 | | | | |
| T | DN 300 | | | | |
| U | DN 350 | | | | |
| V | DN 400 | | | | |
| X | DN 500 | | | | |
| Y | DN 600 | | | | |
| Z | DN 700 | | | | |
| 2 | DN 800 | | | | |
| 3 | DN 900 | | | | |
| 4 | DN 1000 | | | | |
| 6 | DN 1100 | | | | |
| 7 | DN 1200 | | | | |

| Material Group | | | | | |
|----------------|----------------------------------|---------------|----------------------------------|----------------|---|
| Body Material | | Disc Material | | Shaft Material | |
| C | Value | C | Value | C | Value |
| A | ASTM A216 Gr. WCB | A | ASTM A216 Gr. WCB | A | ASTM A564 Grade 630 (17-4 PH) - double heat treated, NACE |
| B | ASTM A351 Gr. CF8M | P | ASTM A216 Gr. WCB nickel plated | B | ASTM A276 Gr. 431 |
| C | UNS J93404 (5A) - Superduplex | B | ASTM A351 Gr. CF8M | D | ASTM A182 Gr. F51 - Duplex, NACE |
| E | ASTM A352 Gr. LCB | C | UNS J93404 (5A) - Superduplex | E | ASTM A453 Gr. 660 for high temperatures |
| F | ASTM A352 Gr. LCC | E | ASTM A352 Gr. LCB | F | Nitronic 50 (XM-19) |
| G | ASTM A217 Gr. WC6 | F | ASTM A352 Gr. LCC | X | Others |
| L | ASTM A351 CT15C (Inconel 800H) | G | ASTM A217 Gr. WC6 | | |
| J | ASTM A484 CY40 (Inconel 600) | L | ASTM A351 CT15C (Inconel 800H) | | |
| K | ASTM A351 CN7M (Alloy 20) | J | ASTM A484 CY40 (Inconel 600) | | |
| H | ASTM A494 N-12MV (Hastelloy B-2) | K | ASTM A351 CN7M (Alloy 20) | | |
| M | ASTM A494 M35-1 (Monel 400) | H | ASTM A494 N-12MV (Hastelloy B-2) | | |
| N | ASTM A351 Gr. CF3M | M | ASTM A494 M35-1 (Monel 400) | | |
| X | Other | N | ASTM A351 Gr. CF3M | | |
| | | X | Other | | |

How to Order

| Type | Gland/ Packing / Top Work | Actuation Group | Option ¹⁾ |
|------|---------------------------|-----------------|----------------------|
| | 1AA- | F- | 001 |

| Seal ring on disc and Seat | |
|----------------------------|--|
| C | Value |
| 1 | ASTM A240 Gr. 318 LN / graphite + seat Stellite 21 |
| 2 | ASTM A240 Gr. 318 LN , laminated w/o graphite + seat stellite 21 |
| X | Others |

| Flange Type | |
|-------------|---|
| Flange Face | |
| C | Value |
| A | Raised face RF acc. ANSI B16.5 |
| 6 | Flat face FF acc. ANSI B16.5 |
| L | Large groove facing LGF acc. ANSI B16.5 (sizes 28"-48") |
| A | Raised face RF acc. B 16.47, series A (sizes 28"-48") |
| B | Raised face RF acc. B 16.47, series B (sizes 28"-48") |
| 6 | Flat face FF acc. ANSI B16.47, Series A (sizes 28"-48") |
| 7 | Flat face FF acc. ANSI B16.47, Series B (sizes 28"-48") |
| L | Large groove facing LGF acc. ANSI B16.47, series A |
| M | Large groove facing LGF acc. ANSI B16.47, series B |
| X | Other |

| Gland / Packing / Top Work Options | | | | | |
|------------------------------------|--------------------------------|---------------------|--|--------------|-------------------------------------|
| Gland Packing | | Packing Box Options | | Gland Flange | |
| C | Value | C | Value | C | Value |
| 1 | Standard Graphite packing | A | Single packing - (standard) | A | Standard gland flange |
| 2 | Low Emissions Graphite packing | F | Single packing with flushing port | B | Chemical gland flange |
| 3 | Reinforced PTFE packing | G | Single packing with pressure tight bearing | C | Standard gland flange - live loaded |
| X | Other | R | Single packing with monitoring port and pressure tight bearing protector | | |
| | | M | Dual packing with monitoring port | | |
| | | P | Dual packing with monitoring and flushing port | | |
| | | T | Dual packing with monitoring port and pressure tight bearing protector | | |
| | | X | Other | | |

| Actuation Group | |
|-----------------|---------------|
| Actuation | |
| C | Value |
| F | Bare shaft |
| G | Gear |
| Y | Scotch Yoke |
| R | Rack & Pinion |
| E | Electric |
| H | Hydraulic |
| X | Other |

C = Code no.

1) Please contact manufacturing site for details

CRANE®

Crane ChemPharma & Energy

Crane ChemPharma & Energy
4526 Research Forest Drive, Suite 400
The Woodlands
Texas 77381, U.S.A.
Tel.: +1 936 271 6500
Fax: +1 936 271 6510

Friedrich Krombach GmbH
Armaturenwerke
Marburger Str. 364
57223 Kreuztal, Germany
Tel: +49 2732 520 00
Fax: +49 2732 520 100

www.cranecpe.com

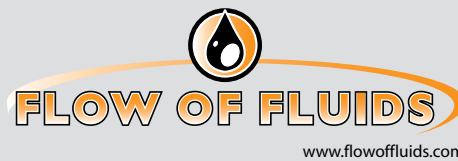

brands you trust.



CPE-CRANE-FKX 9000-BU-EN-A4-2017_04_07

Crane Co. and its subsidiaries cannot accept responsibility for possible errors in catalogues, brochures, other printed materials, and website information. Crane Co. reserves the right to alter its products without notice, including products already on order provided that such alteration can be made without changes being necessary in specifications already agreed. All trademarks in this material are property of the Crane Co. or its subsidiaries. The Crane and Crane brands logotype, in alphabetical order, (ALOYCO®, CENTER LINE®, COMPAC-NOZ®, CRANE®, DEPA®, DUO-CHEK®, ELRO®, FLOWSEAL®, JENKINS®, KROMBACH®, NOZ-CHEK®, PACIFIC VALVES®, RESISTOFLEX®, REVO®, SAUNDERS®, STOCKHAM®, TRIANGLE®, UNI-CHEK®, WTA®, and XOMOX®) are registered trademarks of Crane Co. All rights reserved.